



Tosca



CLASS B	ANNUAL ENERGY 70 kWh
FINO A - UP TO 700 m ³ /h	MAX PRESSURE 520 Pa

CARATTERISTICHE - FEATURES

Misura - Size	90 cm
Materiale - Material	Corpo bianco antico, profilo in legno neutro tinteggiabile body ancient white, profile in neutral wood to be painted
Controlli - Controls	pulsantiera slider slider control
Funzioni - Functions	3 velocità 3 speed
Luci Lights	LED 2x3W LED 2x3W
Aspirazione Extraction	estesa sul piano orizzontale extended on horizontal plan
Uscita aria - Duction	120 - 150 mm con valvola di non ritorno 120 - 150 with check valve
Tipo d'uso - Type	aspirante - filtrante duction - filtered
Filtro antigrasso Grease filter	in alluminio multistrato lavabile in aluminium multilayer, washable
Minima distanza Min. Distance from hob	65 cm

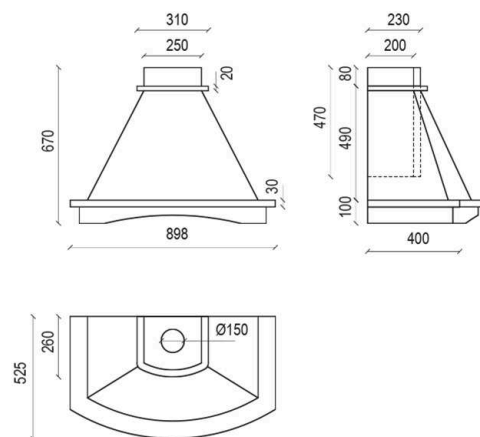

DIMENSIONI SCATOLA - BOX SIZE 95 x 56 x 71 cm - 21 Kg

FILTRI OPTIONAL - OPTIONAL FILTERS

Filtro antiodori 2 su i lati motore ai carboni attivi
Charcoal filter 2 filters on side of motor

02FCCARBGRUP

VERSIONI - VERSION

cm. 90 - bianco antico - ancient white - 700m³/h
01TOS090WH70NT